

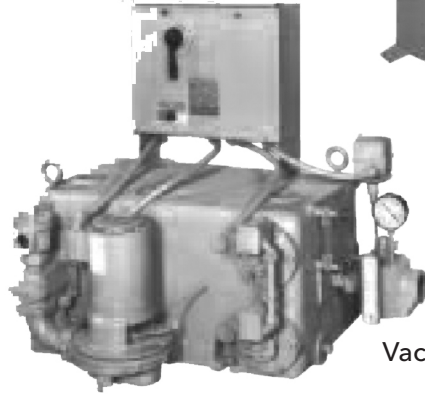

Condensate Units



Boiler Feed Units



Vacuum Heating Units

Hoffman Specialty[®] Pump Products

INDEX

Condensate Return Units

Series WC™ – Stock Watchman® Condensate Units to 12,000 Sq. Ft. EDR Cast Iron Receivers	Pages 3-6
Series WCS™ – Stock Watchman® Condensate Units to 12,000 Sq. Ft. EDR Steel Receivers	Pages 3-6
Series SCC™ – Stock Units 15, 22 and 45,000 Sq. Ft. EFT @ 30 psi Cast Iron Receivers	Page 7

Boiler Feed Units

Series VBF™ – Stock Boiler Feed Units up to 200 BHP	Pages 8-9
Series HBF™ – Stock Boiler Feed Units up to 200 BHP	Page 10
Series HBF™ – Built-to-Order Boiler Feed Unit up to 200 BHP	Pages 11-13
Built-To-Order – Condensate, Return, Boiler Feed & Vacuum Units	Pages 14-15

$$\frac{\text{Sq. Ft. EDR}}{4} = \text{Lbs./hr.}$$

$$\text{BHP (Boiler Horsepower)} \times 139 = \text{Sq. Ft. EDR}$$

SERIES WC™ THE WATCHMAN TRADITION

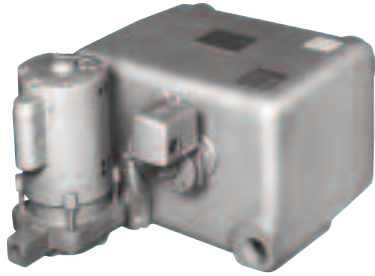

Single Units
WC-8-20B &
WC-12-20B



Single Unit
WC-6-20B

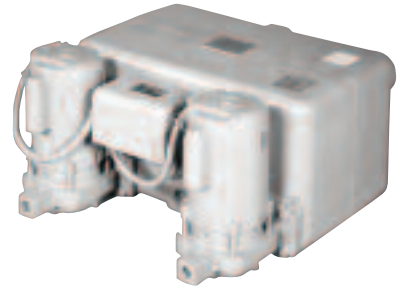

Duplex Unit
WCD-12-20B

20 Year Warranty
Cast Iron Receivers

SERIES WCS™ THE NEW ERA OF WATCHMAN TRADITION

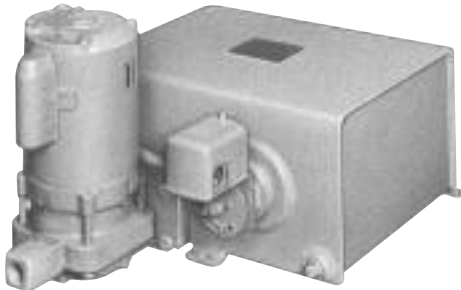

3-Simplex Units
WCS 6, 8 & 12-20B



Duplex Unit
WSCD12-20B

Durable Lightweight
Steel Receivers

Hoffman™ Watchman® Series WC™ 6,000, 8,000, 12,000 and 30,000 Sq. Ft. EDR
and WCS™ Condensate Units 6,000, 8,000 and 12,000 Sq. Ft. EDR

Simplex and Duplex Designs

14 Solid Reasons to Choose Hoffman:

- Engineered reliability.
- Close-grained, corrosion resistant cast iron receivers.
- Durable, lightweight steel receivers
- NPT inlet, vent and overflow receiver openings.
- Durable float actuated mechanical alternator standard on duplex units.
- Field-tested performance. Thousands installed and operating economically and efficiently.
- Close-coupled pump design.
- Carbon/ceramic mechanical seal construction.
- Quiet, ball-bearing type motor with dual voltage and thermal overload protection.
- Bronze-fitted centrifugal pump.
- Stainless steel shaft.
- Renewable bronze wearing ring.
- Factory wired and tested pump and motor assembly.

Hoffman Reliability and Dependable Quality. Mechanical Seal Pump Design

Mechanical seal design may be used in vacuum systems.

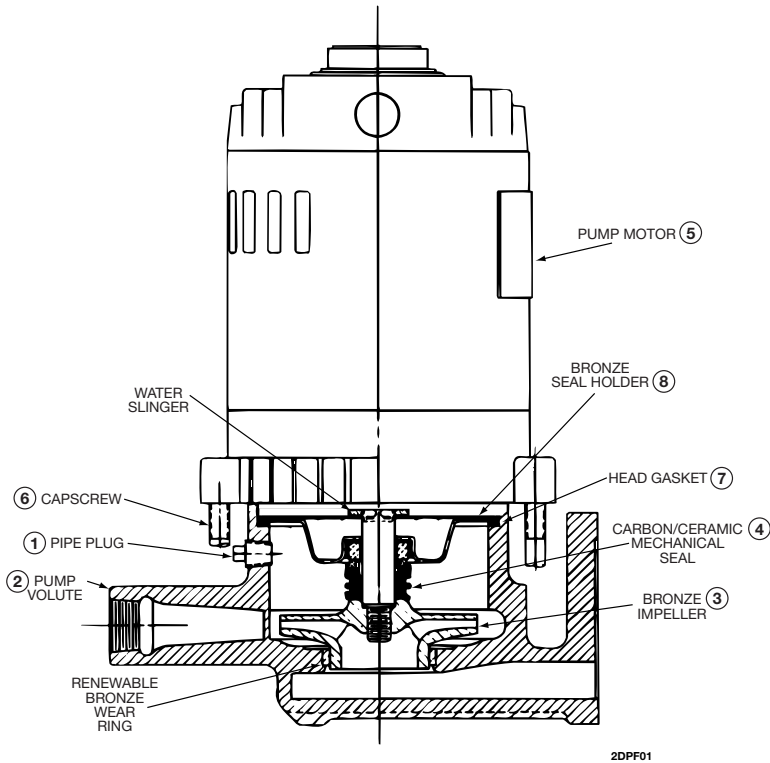

ITEM	QTY.	DESCRIPTION	PART NO.
1	1	Plug	P39040
2	1	Volute & WR ASM Watchman	DP1665
3	1	Impeller 3 ¹¹ / ₁₆ Dia.	DP0321
4	1	Seal and Gasket Kit	180013
5	1	Motor	DM0005
6	4	Capscrew	DJ0083
7	1	Gasket	DG0092
8	1	Seal Holder	DP1966

1/3 HP Pump Construction Detail

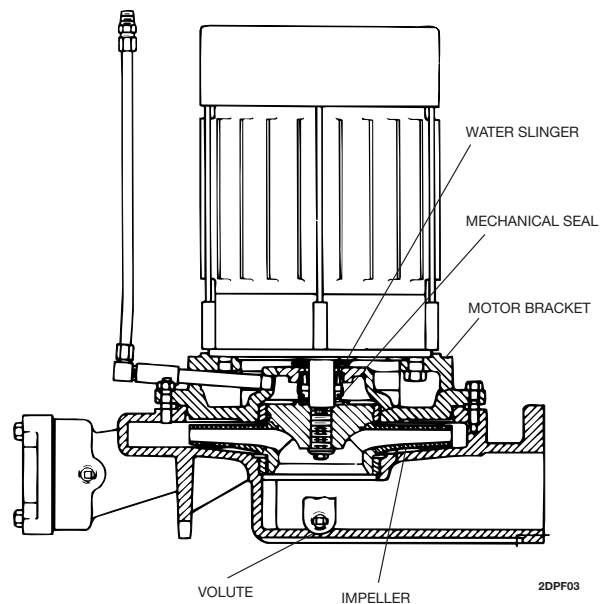

1 HP Pump Construction Detail

Selection Tables

WATCHMAN® SERIES WC™ CAST IRON RECEIVER CONDENSATE UNITS –

3500 RPM, 1 Phase 115V, Mechanical Seal Cast Iron Receiver warranted against failure due to corrosion for 20 years from date of shipment

Model Number	System Sq. Ft. EDR	Number of Pumps	Disch. Pres. (psig)	Pump Capacity (GPM)	Receiver Capacity (Gal.)	Motor HP	Accessories
WC-6-20-B	6,000	Single	22	9	6	1/3	Float switch
WC-8-20-B	8,000	Single	21	12	9	1/3	Float switch
WC-12-20-B	12,000	Single	20	18	14	1/3	Float switch
WCD-12-20-B MA	12,000	Duplex	20	18	14	1/3	Mechanical alternator
WCD-30-30-B MA	30,000	Duplex	30	30	23	1	Mechanical alternator

Watchman condensate units are factory wired for 115 volts and may be field converted to 230 volts 1 phase.

WATCHMAN® SERIES WCS™ STEEL RECEIVER CONDENSATE UNITS –

3500 RPM, 1 Phase 115V, Mechanical Seal, Lightweight, Durable, Steel Receiver

Model Number	System Sq. Ft. EDR	Number of Pumps	Disch. Pres. (psig)	Pump Capacity (GPM)	Receiver Capacity (Gal.)	Motor HP	Accessories
WCS-6-20-B	6,000	Single	22	9	6	1/3	Float switch
WCS-8-20-B	8,000	Single	21	12	9	1/3	Float switch
WCS-12-20-B	12,000	Single	20	18	14	1/3	Float switch
WCDS-12-20-B MA	12,000	Duplex	20	18	14	1/3	Mechanical alternator

Watchman condensate units are factory wired for 115 volts and may be field converted to 230 volts 1 phase.

Suggested Specifications for Hoffman Watchman® Condensate Units

Series WC™ Cast Iron Receiver

Furnish and install according to the plans and manufacturer's instructions the quantity of Hoffman Watchman Series WC () Simplex or () Duplex Condensate Units as shown on the drawings and plans. Each unit shall consist of (1) cast iron receiver, (1) or (2) water pump(s) and float actuated pump switch as hereafter specified.

The condensate receiver shall be of close grain cast iron construction warranted for 20 years from date of shipment against failure due to corrosion. Receiver shall be equipped with:

- a. Simplex Unit – (1) Externally adjustable 2-pole float switch.
or
- b. Duplex Unit – (1) Externally adjustable mechanical alternator to automatically alternate operation of the two pumps and provide simultaneous operation of both pumps to deliver double capacity under peak conditions.

Receiver shall be sized for 1 minute net storage based upon system return rate. Receiver shall have an inlet, vent and an overflow opening to provide a means of secondary venting.

The centrifugal pump(s) shall be flange mounted on the receiver. Pump(s) shall be close coupled vertical design, permanently aligned, bronze fitted and be equipped with stainless steel shaft, enclosed bronze impeller, renewable bronze wear ring and carbon/ceramic mechanical seal.

Each pump shall be close coupled to a vertical dripproof motor. Motor(s) shall be 1/3 - 1HP as specified above, 3500 RPM, single phase, 115/230 volt; factory wired for 115 volts; field convertible to 230 volts. Motor shall have internal thermal overload protection. Pump(s) shall be so constructed to permit access to the impeller and other interior parts without breaking the discharge pipe connections. Pump capacity shall be 9, 12 or 15 gpm at a minimum of 20 psi discharge pressure or 30 gpm at a minimum of 30 psi discharge pressure.

Each unit shall be factory tested. The manufacturer shall furnish complete elementary piping diagrams and installation and operation instructions.

Unit shall be a Hoffman™ Series WC™ as manufactured by ITT R&CW, Morton Grove, IL.

Series WCS™ Steel Receiver

Furnish and install according to the plans and manufacturer's instructions the quantity of Hoffman Watchman Series WCS () Simplex or () Duplex Condensate Units as shown on the drawings and plans. Each unit shall consist of (1) steel receiver, (1) or (2) water pump(s) and float actuated pump switch as hereafter specified.

The condensate receiver shall be of 3/16" steel construction and shall be equipped with mounting feet to mount the unit in place and to keep the receiver off floor thus minimizing corrosion formation.

Unit shall be equipped with:

- a. Simplex Unit – (1) Externally adjustable 2-pole float switch.
or
- b. Duplex Unit – (1) Externally adjustable mechanical alternator to automatically alternate operation of the two pumps and provide simultaneous operation of both pumps to deliver double capacity under peak conditions.

Receiver shall be sized for 1 minute net storage based upon system return rate. Receiver shall have an inlet, vent and an overflow opening to provide a means of secondary venting.

The centrifugal pump(s) shall be flange mounted on the receiver. Pump(s) shall be close coupled vertical design, permanently aligned, bronze fitted and be equipped with stainless steel shaft, enclosed bronze impeller, renewable bronze wear ring and carbon/ceramic mechanical seal.

Each pump shall be close coupled to a vertical dripproof motor. Motor(s) shall be 1/3 HP, 3500 RPM, single phase, 115/230 volt; factory wired for 115 volts; field convertible to 230 volts. Motor shall have internal thermal overload protection. Pump(s) shall be so constructed to permit access to the impeller and other interior parts without breaking the discharge pipe connections. Pump capacity shall be 9, 12 or 15 gpm at a minimum of 20 psi discharge pressure.

Each unit shall be factory tested. The manufacturer shall furnish complete elementary piping diagrams and installation and operation instructions.

Unit shall be a Hoffman™ Series WCS™ as manufactured by ITT R&CW, Morton Grove, IL.

Typical Installation

NOTE - ENTIRE MAIN RETURN MUST HAVE A GRADUAL PITCH DOWN TOWARDS THE INLET

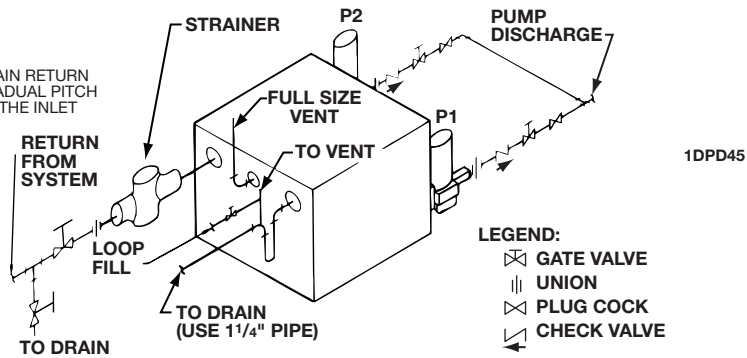

Watchman® Series WC™ Roughing-In Dimensions (All dimensions in inches)

EDR	Style	Rec. Cap	A	B	C
6,000	Single	6	89/16	71/16	611/16
8,000	Single	9	107/8	93/8	9

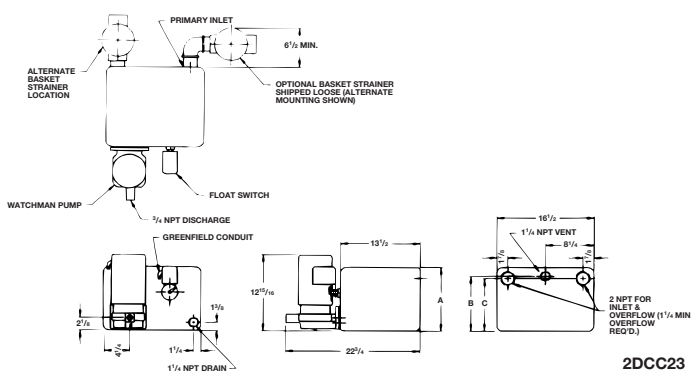

Model WC-6-20B and WC-8-20B - 6 & 9 Gallon Receivers C.I.

Watchman® Series WCS™ Roughing-In Dimensions (All dimensions in inches)

EDR	Style	Rec. Cap	A	B	C
6,000	Single	6	89/16	71/16	611/16
8,000	Single	9	107/8	93/8	9

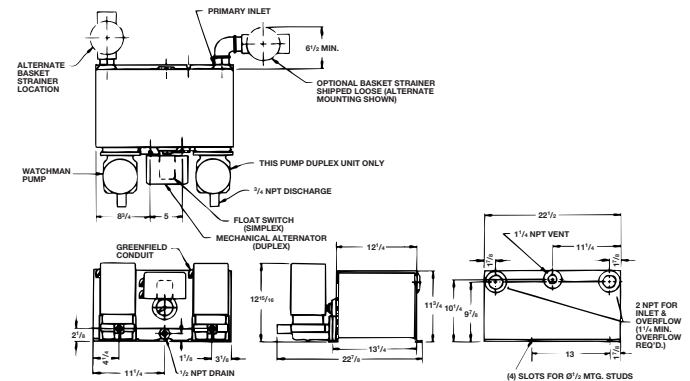

12,000 Sq. Ft. EDR Simplex & Duplex Units
Model WCS-12-20B and WCS-8-20B MA - 14 Gallon Steel

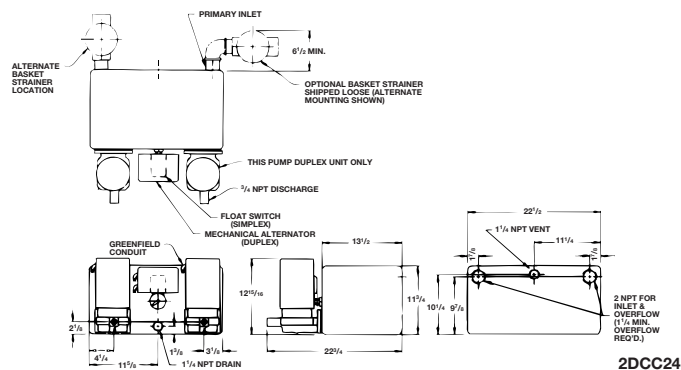

12,000 Sq. Ft. EDR Simplex & Duplex Units
Model WC-12-20B and WCD-12-20B MA - 14 Gallon C.I.

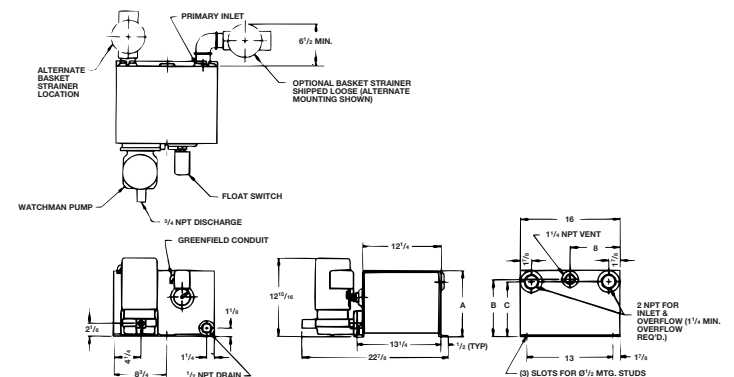

Model WCS-6-20B and WCS-8-20B Steel

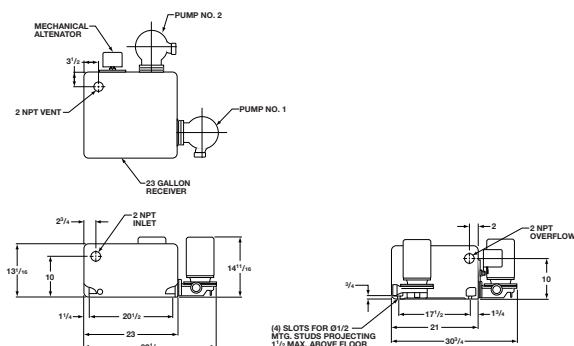

Model WC-30-30B MA - 23 Gallon Receivers



**SCC1 Condensate Unit
Duplex With Mechanical Alternator**

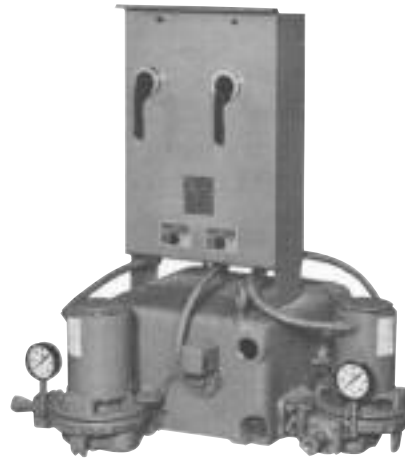

**SCC2, SCC3 or SCC4 Condensate
Unit With Mechanical
Alternator and Control Panel**

20 Year Warranty

Cast Iron Receivers

Hoffman™ Series SCC™ Stock Condensate Return Units

Condensate Units – 3500 RPM, Duplex, Mechanical Seal, 20 Year Warranty Cast Iron Receiver

Model Number	System Sq. Ft. EDR	Disch. Pres. (psig)	Pump Capacity (GPM)	Receiver Capacity (Gal.)	Motor HP	Accessories Power Supply*	(Control Panels are NEMA2 – UL Listed)
SCC1	15,000	30	15	14	3/4	1 Ph - 115 or 230 Volt	Mechanical alternator
SCC2-A	15,000	30	15	14	3/4	3 Ph - 208, 230 or 460 Volt	Mechanical alternator Control Panel w/Magnetic starters
SCC3-B	22,000	30	22	23	3/4	3 Ph - 208, 230 or 460 Volt	Mechanical alternator Control Panel w/Magnetic starters
SCC4-A	45,000	30	45	36	1 1/2	3 Ph - 208, 230 or 460 Volt	Mechanical alternator Control Panel w/Magnetic starters

*SCC1 unit is factory wired for 115 volts and may be field converted to 230 volts.

SCC2, SCC3 & SCC4 units are factory wired for 230 volts. Conversion kits must be used to field modify for 208 or 460 volt.

Roughing-In Dimensions (All dimensions in inches)

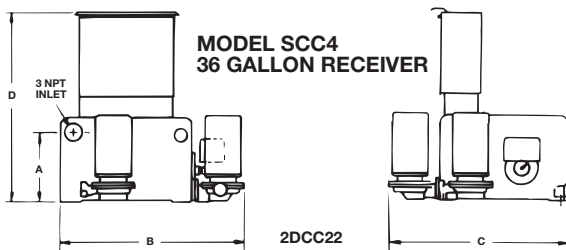
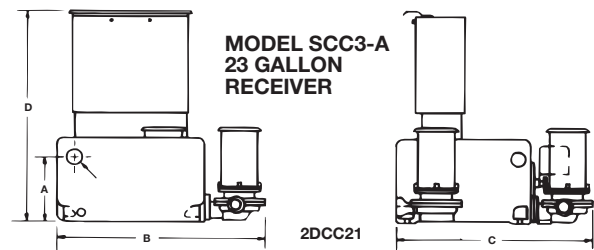
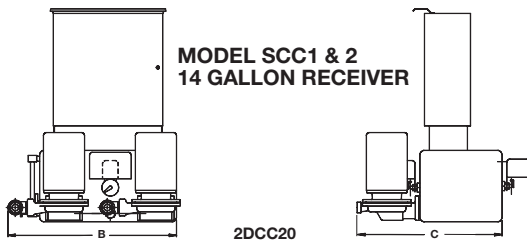

Rec. Cap Gallons	A Inlet Height	Inlet Size (NPT)	B Max.	C Max.	D Incl. Cabinet	Vent & Overflow (NPT)
14	9 7/8	2	29 3/8	22 31/32	35	1 1/4
23	10	2	32 1/2	30 3/4	32 13/16	2
36	13	3	34 1/2	33 1/2	35 3/4	2

All dimensions in inches

All Available from Stock

Hoffman™ Series VBF™ Stock Boiler Feed Pumps

THE Recognized Name in Boiler Feed Pumps

Quality Features that Make Hoffman The Leader

Availability:

Normally Factory or Local Stock

Corrosion Resistance:

Heavy Gauge Steel Receiver
Receiver Mounting Feet
Inlet Baffle

Ease of Installation:

Inlet, Vent and Overflow Openings
Gauge Glass

Ease of Service:

Vertical pull-out pumps
Carbon/Ceramic Mechanical Seals
Flange Mounted pumps
Drain connection

Series VBF Standard Features to Compare

- Inlet**
Low height, NPT Inlet for easy return line piping. Internally baffled to prevent corrosion.
- Make-Up Valve**
Float operated, internal water make-up valve to add water at low level. Lever adjustment is standard.
- Mounting Feet**
To mount unit in place and to keep unit off floor thus preventing corrosion formation.
- Drain Connection**
NPT drain connection to allow removal if water during servicing.

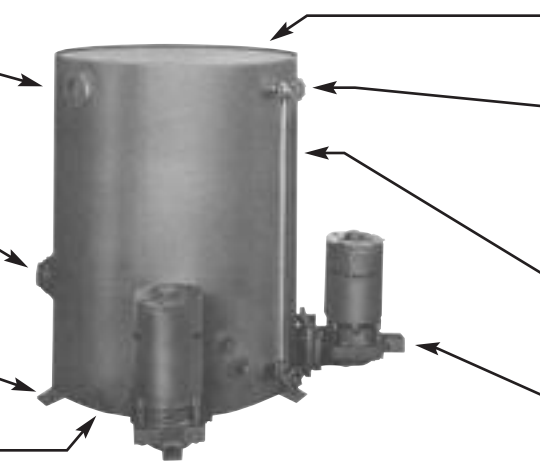

- Vent & Overflow**
Separate NPT connections to provide means of secondary venting.
- Vertical Receiver**
To conserve floor space. Heavy gauge steel for corrosion prevention. Sized to hold approximately 10 minutes of boiler water needs. Has simplex, duplex or triplex pump openings.
- Water Level Gauge Glass**
To indicate water level in receiver. Complete with protective brass rods and shut off valves.
- Centrifugal Pumps**
Built to handle high temperature 200°F condensate. Pumps use carbon/ceramic mechanical seals designed for 250°F temperatures for maximum life.

Optional Features
Inlet Basket Strainers or "Y" Strainers.
Angle or Dial Thermometers.
Control Panels for wall mounting.

Series VBF Selection Chart

Select According to Boiler HP **Ordering Instructions:** Specify Single (1 Pump), Duplex (2 Pumps), Triplex (3 Pumps) and Unit Model No.

Model No. & (No. of Pumps)	SYSTEM RATING				UNIT RATING			DESCRIPTION					
	Boiler HP	GPM	Lbs./Hr.	Sq. Ft. E.D.R.	Pump GPM	Disch. PSI	Motor HP	Receiver Cap. in Gallons		Min. Storage	Inlet Size (Inches)	Discharge Size (Inches)	Inlet Height (Inches)
30 VBF (1) or (2)	10 to 30	2.1	1035	4,200	9	20	1/3	30	18	9	2	3/4	17 3/4
50 VBF (1) or (2)	35 to 50	3.5	1725	7,000	15	20	1/3	50	39	11	2	3/4	27 3/4
100 VBF (1) or (2)	60 to 100	6.9	3400	13,800	15	20	1/3	100*	83	11	2	3/4	33 3/4
200 VBF (1) or (2)	125 to 200	13.8	6900	27,800	30	20	1/2	200*	172	12	2	1 1/2	45 3/4
200 VBF (1) or (2)	125 to 200	13..8	6900	27,800	30	30	1	200*	172	12	2	1 1/2	45 3/4

All motors 1 phase, 60 cycle, 115/230 volt, 3500 RPM as standard. 3 phase motors available on special request.
*100 and 200 gallon receivers are supplied with additional flanged opening for field modification to Triplex arrangement.

Series VBF Roughing-In Dimensions

(All dimensions in inches)

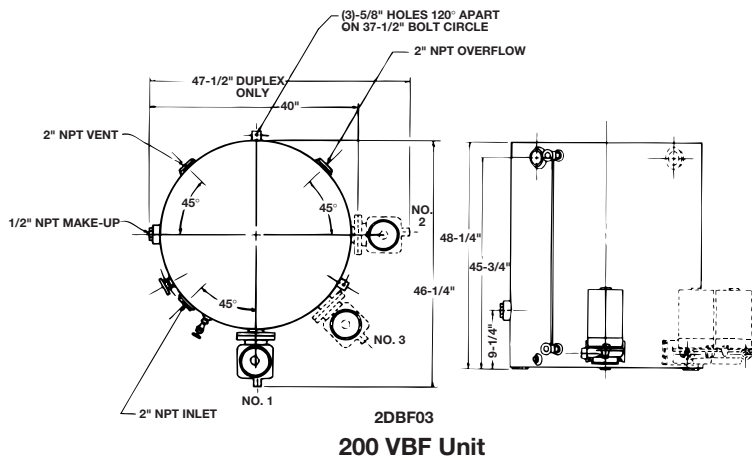
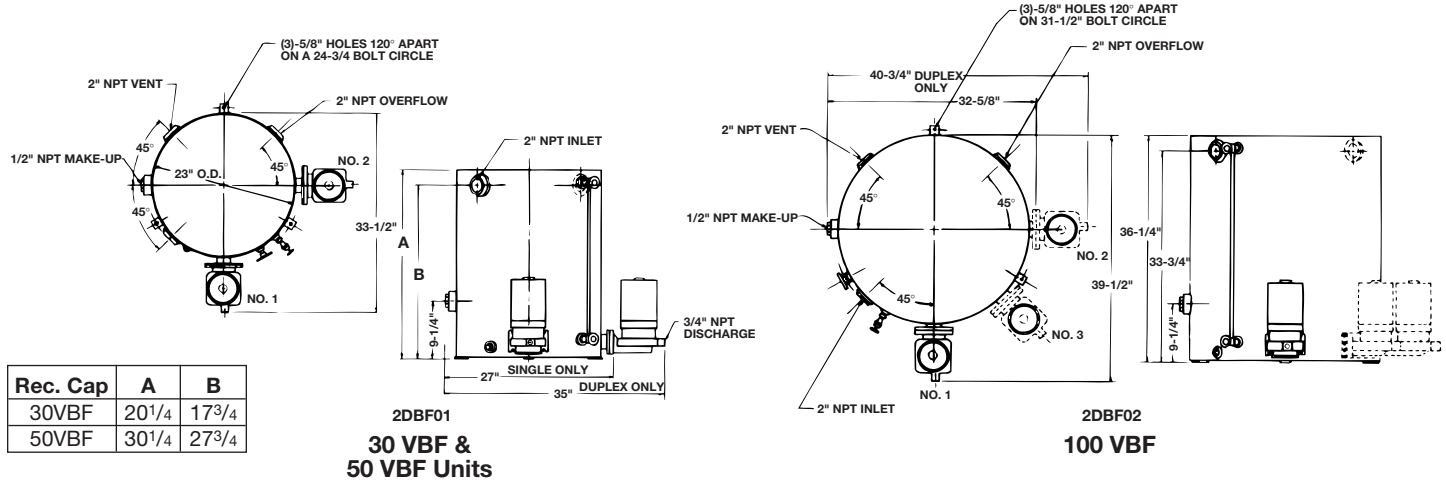

Series VBF Specification

Furnish and install according to manufacturer's instructions the quantity of (single) (duplex) or triplex boiler feed units as shown on the drawings. Each unit shall consist of (1) vertical steel receiver, (1), (2) or (3) pump(s), make-up water valve and water level gauge.

The receiver shall be fabricated of black steel and shall be equipped with a float operated adjustable make-up water valve.

The centrifugal water pump(s) shall be flange mounted on the receiver. The pump shall be of the close coupled vertical design, permanently aligned and bronze fitted, and shall be equipped with a close bronze impeller, renewable bronze casing ring and carbon/ceramic mechanical shaft seal. Motor shaft shall be stainless steel. Each pump shall be close coupled to a drip proof motor. Motor voltage shall be 1 phase 115/230 volt.

The unit shall be factory tested as a complete unit. The pump manufacturer shall furnish installation.operation manuals.

Unit shall be a Hoffman™ Series VBF™ as manufactured by ITT R&CW, Morton Grove, IL.

Capacity Schedule

Series VBF Boiler Feed Unit(s):

Catalog No.: _____ VBF

Capacity: _____ gpm @ _____ psig

Receiver: _____ Gallons

Motors: _____ Hp, 3500 RPM, ODP

Electrical: Single Phase, 60 Hertz, Wired for 115 volts
(field convertible to 230 volts)

Hoffman™ Series HBF™ Stock Boiler Feed Units

THE Recognized Name in Boiler Feed Pumps



HBF Stock Products – Open Drip Proof Motors Only. Single Phase 115/230V.

SIMPLEX UNITS							
Boiler Horsepower	50	100		200			
Model	50HBFS-1520	100HBFS-1520	100HBFS-2030	200HBFS-3020	200HBFS-3030	200HBFS-4020	200HBFS-4030
Part Number	161051	161053	161055	161057	161059	161061	161063
Capacity, GPM	15	15	20	30	30	40	40
Discharge Pressure, psig	20	20	30	20	30	20	30
Mtr HP, 3500 RPM, 115/1/60	1/3	1/3	3/4	1/2	1	1	1-1/2
Receiver capacity, gal.	50	100	100	200	200	200	200

DUPLEX UNITS							
Boiler Horsepower	50	100		200			
Model	50HBFD-1520	100HBFD-1520	100HBFD-2030	200HBFD-3020	200HBFD-3030	200HBFD-4020	200HBFD-4030
Part Number	161052	161054	161056	161058	161060	161062	161064
Capacity, GPM	15	15	20	30	30	40	40
Discharge Pressure, psig	20	20	30	20	30	20	30
Mtr HP, 3500 RPM, 115/1/60	1/3	1/3	3/4	1/2	1	1	1-1/2
Receiver capacity, gal.	50	100	100	200	200	200	200

Series HBF Standard Features

HoffGuard™: Corrosion resistance coating gives additional protection to the heavy gauge steel receiver.

Centrifugal Pumps: Rated for high temperature 210°F (99°C) condensate. Operates with as little as 2' NPSH. Pumps include carbon/ceramic mechanical seals designed for 250°F (121°C) for maximum life.

Horizontal Receivers: Lowest inlet design for retrofit in existing applications with low return lines. Sized for a minimum of 5 minutes storage. All receivers have 2 pump openings.

Make-up Valve: Float operated, internal water make-up valve adds cold water at low level. Level adjustment is standard.

Vent and Overflow: Separate NPT connections to provide a secondary vent ensuring safe operation.

Water Level Gauge Glass: Includes protective brass rods and shut off valve.

ISO 9001 Certified: The HBF is produced in our ISO 9001 certified manufacturing facility. ISO certification assures a product built with a consistent level of quality and performance.

Series HBF Optional Features

- Control Panel
- Inlet Basket Strainer
- “Y” Strainer
- Dial Thermometer
- Pressure Gauges
- Butterfly Valves

Hoffman™ Series HBF™ Boiler Feed Units Built To Order



Series HBF Selection Chart

Model Number	SYSTEM RATING			UNIT RATING					
	Maximum BHP (kW)	Sq. ft. E.D.R.	System Flow GPM (LPM)	Pump Description Flow GPM (LPM)	Pressure PSI (Bar)	Motor HP (kW)	Tank Size* Gallons (Liters)	Minutes of Storage	Pump Model
50HBF(S/D)-0920	64 (7)	9000	4.5 (17)	9 (34)	20 (1.4)	1/3 (0.25)	50 (189)	5	609PF
50HBF(S/D)-0925	64 (7)	9000	4.5 (17)	9 (34)	25 (1.7)	1/2 (0.37)	50 (189)	5	616PF w/Orifice
50HBF(S/D)-0930	64 (7)	9000	4.5 (17)	9 (34)	30 (2.0)	3/4 (0.56)	50 (189)	5	616PF w/Orifice
100HBF(S/D)-0920	64 (7)	9000	4.5 (17)	9 (34)	20 (1.4)	1/3 (0.25)	110 (416)	12	609PF
100HBF(S/D)-0925	64 (7)	9000	4.5 (17)	9 (34)	25 (1.7)	1/2 (0.37)	110 (416)	12	616PF w/Orifice
100HBF(S/D)-0930	64 (7)	9000	4.5 (17)	9 (34)	30 (2.0)	3/4 (0.56)	110 (416)	12	616PF w/Orifice
100HBF(S/D)-1520	107 (11)	15000	7.5 (28)	15 (57)	20 (1.4)	1/3 (0.25)	110 (416)	7	609PF
100HBF(S/D)-1525	107 (11)	15000	7.5 (28)	15 (57)	25 (1.7)	1/2 (0.37)	110 (416)	7	616PF w/Orifice
100HBF(S/D)-1530	107 (11)	15000	7.5 (28)	15 (57)	30 (2.0)	3/4 (0.56)	110 (416)	7	616PF w/Orifice
100HBF(S/D)-2020	143 (15)	20000	10.0 (38)	20 (76)	20 (1.4)	1/3 (0.25)	110 (416)	5	609PF
100HBF(S/D)-2025	143 (15)	20000	10.0 (38)	20 (76)	25 (1.7)	3/4 (0.56)	110 (416)	5	616PF
100HBF(S/D)-2030	143 (15)	20000	10.0 (38)	20 (76)	30 (2.0)	3/4 (0.56)	110 (416)	5	616PF
200HBF(S/D)-2520	179 (18)	25000	12.5 (47)	25 (95)	20 (1.4)	3/4 (0.56)	220 (833)	8	616PF
200HBF(S/D)-2525	179 (18)	25000	12.5 (47)	25 (95)	25 (1.7)	3/4 (0.56)	220 (833)	8	616PF
200HBF(S/D)-2530	179 (18)	25000	12.5 (47)	25 (95)	30 (2.0)	1 (0.75)	220 (833)	8	616PF
200HBF(S/D)-3020	214 (22)	30000	15.0 (57)	30 (114)	20 (1.4)	3/4 (0.56)	220 (833)	7	616PF
200HBF(S/D)-3025	214 (22)	30000	15.0 (57)	30 (114)	25 (1.7)	3/4 (0.56)	220 (833)	7	616PF
200HBF(S/D)-3030	214 (22)	30000	15.0 (57)	30 (114)	30 (2.0)	1 (0.75)	220 (833)	7	616PF
200HBF(S/D)-4020	286 (29)	40000	20.0 (76)	40 (151)	20 (1.4)	1 (0.75)	220 (833)	5	626PF
200HBF(S/D)-4025	286 (29)	40000	20.0 (76)	40 (151)	25 (1.7)	1 1/2 (1.12)	220 (833)	5	626PF
200HBF(S/D)-4030	286 (29)	40000	20.0 (76)	40 (151)	30 (2.0)	1 1/2 (1.12)	220 (833)	5	626PF

*300 Gallon size available on request. All Motors 1 Phase, 60 Cycle, 115/230 Volt, 3500 RPM.

Series HBF Standard Features

HoffGuard™: Corrosion resistance coating gives additional protection to the heavy gauge steel receiver.

Centrifugal Pumps: Rated for high temperature 210°F (99°C) condensate. Operates with as little as 2' NPSH. Pumps include carbon/ceramic mechanical seals designed for 250°F (121°C) for maximum life.

Horizontal Receivers: Lowest inlet design for retrofit in existing applications with low return lines. Sized for a minimum of 5 minutes storage. All receivers have 2 pump openings.

Make-up Valve: Float operated, internal water make-up valve adds cold water at low level. Level adjustment is standard.

Vent and Overflow: Separate NPT connections to provide a secondary vent ensuring safe operation.

Water Level Gauge Glass: Includes protective brass rods and shut off valve.

ISO 9001 Certified: The HBF is produced in our ISO 9001 certified manufacturing facility. ISO certification assures a product built with a consistent level of quality and performance.

Series HBF Optional Features

- Control Panel
- Inlet Basket Strainer
- “Y” Strainer
- Dial Thermometer
- Pressure Gauges
- Butterfly Valves

Elementary Piping Diagram

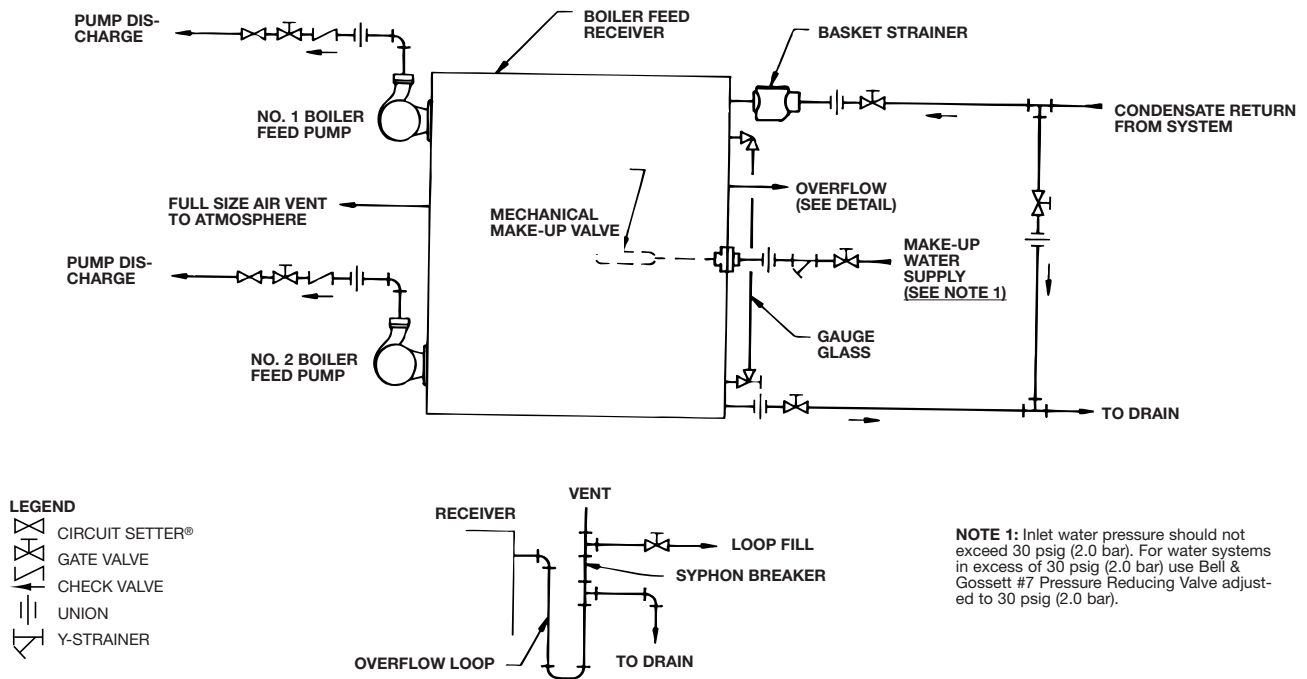

Series HBF Specification

NOTE: Optional accessories are underlined.

Furnish and install according to manufacturer's instructions the quantity of boiler feed units as shown on the drawings. Each unit shall consist of (1) horizontal steel receiver, 1 pump (simplex) or 2 pumps (duplex), adjustable mechanical make-up water valve and water level gauge glass.

The receiver shall be fabricated of black steel with HoffGuard™ coating for added corrosion resistance. The receiver shall be horizontal for the lowest possible inlet. The receiver shall include a separate inlet, vent, and overflow connection. The pumps shall be located on the receiver head to minimize the units width to allow passage through a 32" (813mm) opening. Accessories installed on the receiver shall include a water level gauge, inlet basket strainer or "Y" strainer, and dial thermometer. Bronze fitted butterfly valves shall be installed between each pump suction and receiver to permit servicing the pumps without draining the receiver. The receiver shall be sized for a minimum of 5 minutes net storage.

The centrifugal pump(s) shall be flange mounted to the receiver. The pumps shall be of the close coupled vertical design, bronze fitted, with renewable bronze casing wear ring. The pumps shall use carbon/ceramic mechanical seals designed for 250°F (121°C) temperatures for maximum life. Discharge pressure gauges shall be included with each pump. The pumps shall be capable of operating with as little as 2' NPSH (net positive suction head) to pump 210°F (99°C) condensate at the rated capacity. The pump motors shall be 3500 RPM vertical open drip proof.

The unit manufacturer shall furnish a wall mounted 115/230 volt single phase simplex control panel for each pump. Each NEMA 4X enclosure shall contain: panel door with interlock, (1) IEC contactor, waterproof on-off switch, and pilot light (indicating pump running). The control cabinet and internal components shall be UL listed.

The receiver size, pump capacities, motor HP, and electrical characteristics shall be as scheduled on the drawings. Each pump shall be sized for 2 times the boiler evaporation rate.

The boiler feed unit will be manufactured by a company that is ISO 9001 certified. The boiler feed unit shall be factory tested. The boiler feed unit shall be Hoffman™ Series HBF as manufactured by ITT R&CW, Morton Grove, IL.

Capacity Schedule

Series HBF Boiler Feed Unit(s)

Model No. _____ HBF _____ - _____

Capacity: _____ gpm (lpm) @ _____ psig (bar)

Receiver: _____ gallons (liters)

Pump Motors: _____ HP (kW), 3500 RPM, ODP

Since 1929, the name Hoffman has been associated with Condensate Transfer Equipment. Today, Hoffman continues to offer standardized product that is locally stocked and a broad selection of Built to Order product. From Condensate Return Units to Boiler Feed Units and Vacuum Heating Units the name Hoffman assures quality, factory tested units, designed for fast easy installation.

Hoffman Warranties ALL CAST IRON RECEIVERS against failure due to corrosion for **20 years** and provides NEMA 2 Control Panels as a standard option.

For more information about Hoffman Pumps or expert assistance in designing or troubleshooting systems, consult your local ITT R&CW Representative.

CONDENSATE RETURN UNITS

Series HC™ or HS™

Condensate return units, for feedwater temperatures to 200°F, and systems up to 150,000 sq. ft. EDR. Simplex or Duplex units, Series HC units include low inlet cast iron receivers for maximum corrosion protection. Series HS units include low inlet, durable and lightweight steel receivers. All pumps are bronze fitted with stainless steel shafts, available in 3500 or 1750 RPM. Discharge pressures to 90 psi.

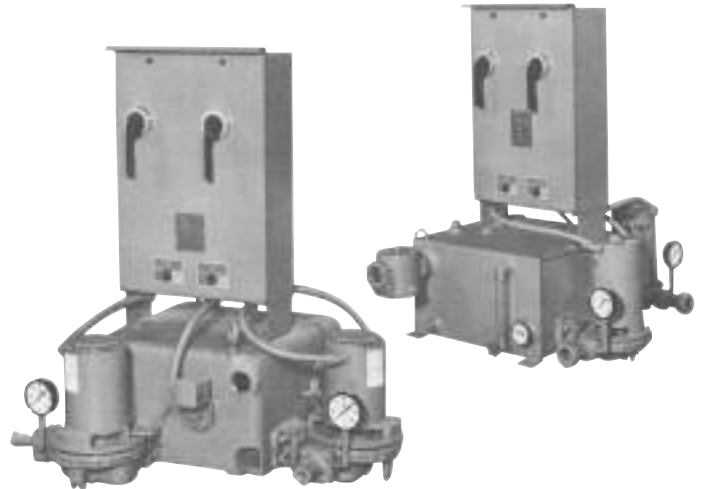

Series UH™

Underground condensate return pumps for use where returns are below grade. For use in systems up to 90,000 sq. ft. EDR and feedwater temperatures up to 200°F. Available in Simplex or Duplex design with cast iron receivers. Centrifugal pumps are bronze fitted with stainless steel shafts. For underground boiler feed units, Series UHM units are available for systems up to 280 BHP.

BOILER FEED UNITS

Series HCM™ or HSM™

Boiler feed units, for feedwater temperatures up to 200°F maximum, for small systems up to 600 BHP, Simplex or Duplex units. Series HCM units include low inlet cast iron receivers for maximum corrosion protection. Series HSM units include low inlet, durable and lightweight steel receivers. All pumps are bronze fitted with stainless steel shafts, available in 3500 or 1750 RPM. Discharge pressures to 90 psi.

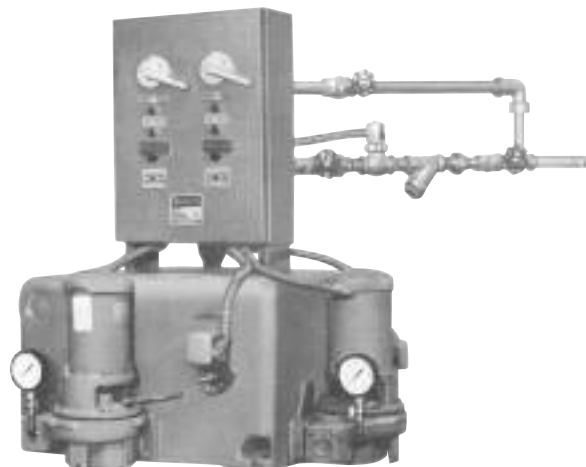

VACUUM HEATING UNITS

Series HV™

Vacuum heating units to provide fast, even distribution of steam throughout steam heating systems. Simplex or Duplex designs with discharge pressures up to 40 psi. Series HV units are available through 20,000 sq. ft. EDR and Series HV units from 25,000 to 65,000 sq. ft. EDR. Both feature compact, economical designs with low inlets and cast iron receivers. For older systems, Special Capacity units are available to provide more air removal capacity.

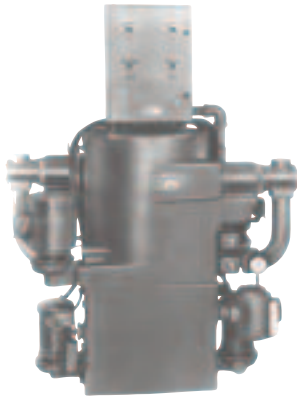
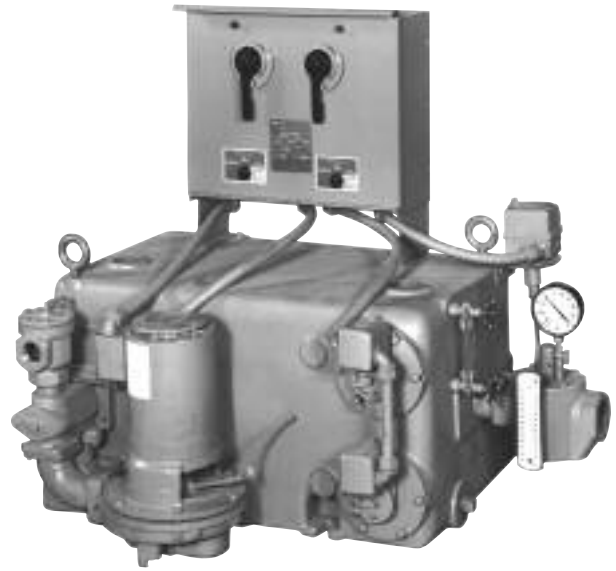

Series VC™

Large vacuum heating units to provide fast, even distribution of steam through steam heating systems. These units feature individually sized and separately controlled air and water pumps to permit maximum flexibility in meeting requirements. Simplex, Semi-Duplex, and Duplex units for systems throughout 150,000 sq. ft. EDR with discharge pressures to 75 psi. Durable cast iron receivers are available in four sizes to accurately match system requirements.

CENTRIFLO® CENTRIFUGAL PUMPS

Centriflo® Series C35™ or C17™

The heart of Hoffman's condensate handling equipment, these bronze fitted pumps are designed with a lower NPSH requirement than conventional pumps but they are also suited for other types of service. Vertical mounting saves floor space and gets the motor above dirt and water. Standard features include stainless steel shafts, enclosed bronze impellers, and carbon/ceramic mechanical seals designed for 250°F for maximum life. Available in 3500 or 1750 RPM. Capacities to 600 GPM and pressures up to 100 psi.



Xylem |'zīləm|

- 1) The tissue in plants that brings water upward from the roots;
- 2) a leading global water technology company.

We're 12,500 people unified in a common purpose: creating innovative solutions to meet our world's water needs. Developing new technologies that will improve the way water is used, conserved, and re-used in the future is central to our work. We move, treat, analyze, and return water to the environment, and we help people use water efficiently, in their homes, buildings, factories and farms. In more than 150 countries, we have strong, long-standing relationships with customers who know us for our powerful combination of leading product brands and applications expertise, backed by a legacy of innovation.

For more information on how Xylem can help you, go to www.xylem.com



Xylem Inc.
8200 N. Austin Avenue
Morton Grove, Illinois 60053
Phone: (847) 966-3700
Fax: (847) 965-8379
www.xylem.com/brands/bellgossett