



## REMOTE SENSOR THERMOSTAT MTWZ



*see reverse for  
min/max field adjustment*

### **Operation**

The sensor on the MTWZ is wax-filled and the wax volume varies according to ambient temperature. The volume changes are transmitted to the valve stem via a liquid capillary system. The valve body has a return spring which closes the valve when the stem is under low pressure. When the force from the sensor and the return spring are balanced to the room temperature selected, the valve disc stops in that position to allow a certain amount of water or steam to flow through the valve. Ambient temperature changes cause the valve disc to change position and thereby continuously modulate the flow so that the room temperature is maintained at the desired temperature. The unit is secured against damage from over-pressure by a built-in pressure absorbing spring.

### **Features and Benefits**

- Valve-mounted setting knob and remote temperature sensor
- Brass sensor, High sensitivity
- Fiberglass valve plug shaft
- Stainless steel capillary tube, 6'6" standard length
- Longer capillary available, consult factory
- Fits all Macon NT series valves
- Replaces the valve-mounted sensors on built-in convectors, etc., and where the valve-mounted sensor is exposed to draft from doors and windows
- Fully automatic - nonelectric, no wiring
- Manufactured to exacting standards using exceptionally high quality materials
- Each sensor is tested and re-checked to achieve exact settings before leaving the factory
- Note that changing the actuator can be accomplished without draining the system
- All Macon thermostats can be locked at or limited to a specific temperature or temperature range
- Simple one-trade installation
- Sensor guard furnished at no extra cost
- All Macon valves and thermostats conform to ASHRAE Standard 102P-1983 and European Standard EN 215/1215. We are also ISO 9001 certified (2002) and ISO 14001 certified (2002).

# MACON SPECIFICATIONS

## MTWZ

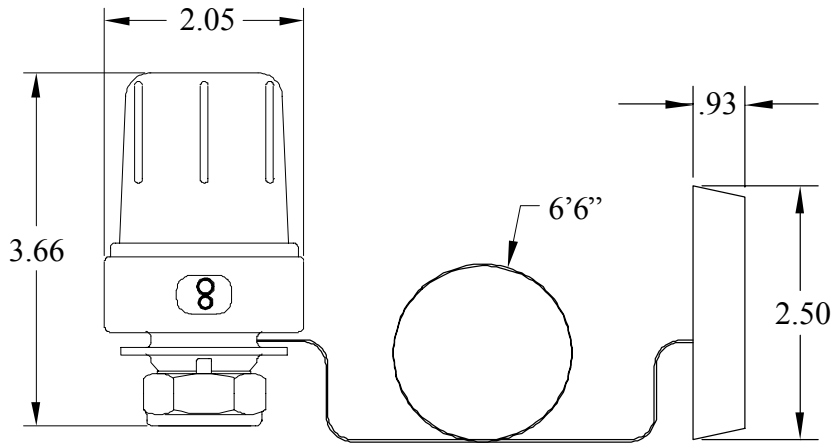

### **DATA**

Temp. Range: 46° - 82°F  
 Hysteresis: 0.9°F  
 Heat Transfer: 1.1°F (Valve Housing Sensor)  
 Dead Time: 0.8 Minutes  
 Max. Differential Pressure: 20 psi  
 Suggested Differential Pressure = 0.5 to 2.9 psi  
 Max. Water Temp.: 250°F  
 Max. Storage & Ambient Temp.: 122°F  
 Max. Steam Pressure: 15 psig  
 Max. Movement: 0.125 inches  
 Long Term Test: 5000 cycles (1.3°F)

Each unit is factory pre-set per the dial settings listed.  
 If field adjustments are necessary see below.

#### Maximum setting

1. Turn the wheel to maximum and a red mark will occur in the indicating window (located opposite the dial setting window).
2. Push the mark in while turning the wheel to desired temperature according to chart below.
3. When desired temperature is reached, let go of the mark and the maximum temperature limit is set.

#### Minimum setting

1. Turn the wheel to minimum and a blue mark will occur in the indicating window (located opposite the dial setting window).
2. Push the mark in while turning the wheel to desired temperature according to chart below.
3. When desired temperature is reached, let go of the mark and the minimum temperature limit is set.

### **DIAL SETTINGS:**

\* = 46°F (Frost Protection)

- 1 = 54°F
- 3 = 61°F
- 5 = 68°F
- 6 = 72°F
- 7 = 76°F
- 8 = 80°F
- 9 = 82°F

